

---

# ***CCTV-Test+***

Pages from ***User Manual***



# 1, Safety Information

## 1.1 Precaution before using the tester

- A. Make sure to read the user's manual before using the product.
- B. Make sure to check the input and output range of voltage or current at every input and output ports before connecting, so that the system cannot be overloaded.
- C. The following operational environment should be maintained constantly:
  - Temperature: -30°C--- 70°C
  - Relative humidity: 30% ~ 90%
  - Recharging voltage: DC5V

## 1.2 Precautions when using the tester

- A. Do not use the tester in damp humidity or leaking gas environments.
- B. Do not touch the tester with wet hands.
- C. Be mindful not to shock or shake the tester while in use to avoid damage.
- D. Avoid the places of strong magnetism or electric wave, which could cause incorrect measuring.
- E. Be careful not to expose the ports or joints to dirt or liquid.
- F. Do not disassemble the tester.

## 1.3 Precautions for battery charging and using

- A. Use only original chargeable battery with the tester, when charge the batteries, please use the original power adapter.
- B. Make sure not to disorient the polarization of batteries.
- C. Do not short-circuit or disassemble batteries.

# 2, Introduction

## 2.1 Features and function

### A. Video test

The video signal and the quality of picture can be tested.

### B. PTZ controlling

It has the basic operational test of PTZ products, function include pan/tilt, zoom in/out, preset setting and operation, speed adjustment etc; support multi-protocol and baud rate, communication via RS-232, RS422 simplex and RS485 port.

RS485 protocol include: Pelco D,P, Samsung, Panasonic, Molyx.

Baud rate include: 2400, 4800, 9600, 19200.

**C. Power to camera**

The tester can output DC12V power to camera; it's a helpful function when testing person can't find power supply when they test a camera.

**D. Digital multi-meter**

The tester can detect the AC/DC voltage and resistance, high testing range and precision can help installer find out the circuit problem.

**E. Video signal attenuation analyzing**

The tester can help installer to analyze the video signal attenuation by catching the video signal parameters.

**F. UTP cable test**

The wiring condition (disconnected, short of UTP cable) can be tested and show in the screen clearly.

**G. Video signal generating**

It can output Green, White, Black or Blue screen to allow technician to inspect video monitor or DVR. The generated signal is NTSC TV format.

**H. RS485 data test**

It can test the RS485 data sent from controlling device, display the hexadecimal data content for engineer to analyze.

## 2.2 Standard items

Item	Quantity
<b>CCTV tester</b>	1
<b>Battery</b>	1
<b>Power Adaptor</b>	Aust/NZ or USA or UK or Euro type
<b>UTP cable tester</b>	1
<b>BNC connect cable</b>	1
<b>Test lead set</b>	1
<b>Necklace</b>	1
<b>Multi-meter cables</b>	2
<b>DC12V power cable</b>	1
<b>User manual</b>	1

## 2.3 Function of each part

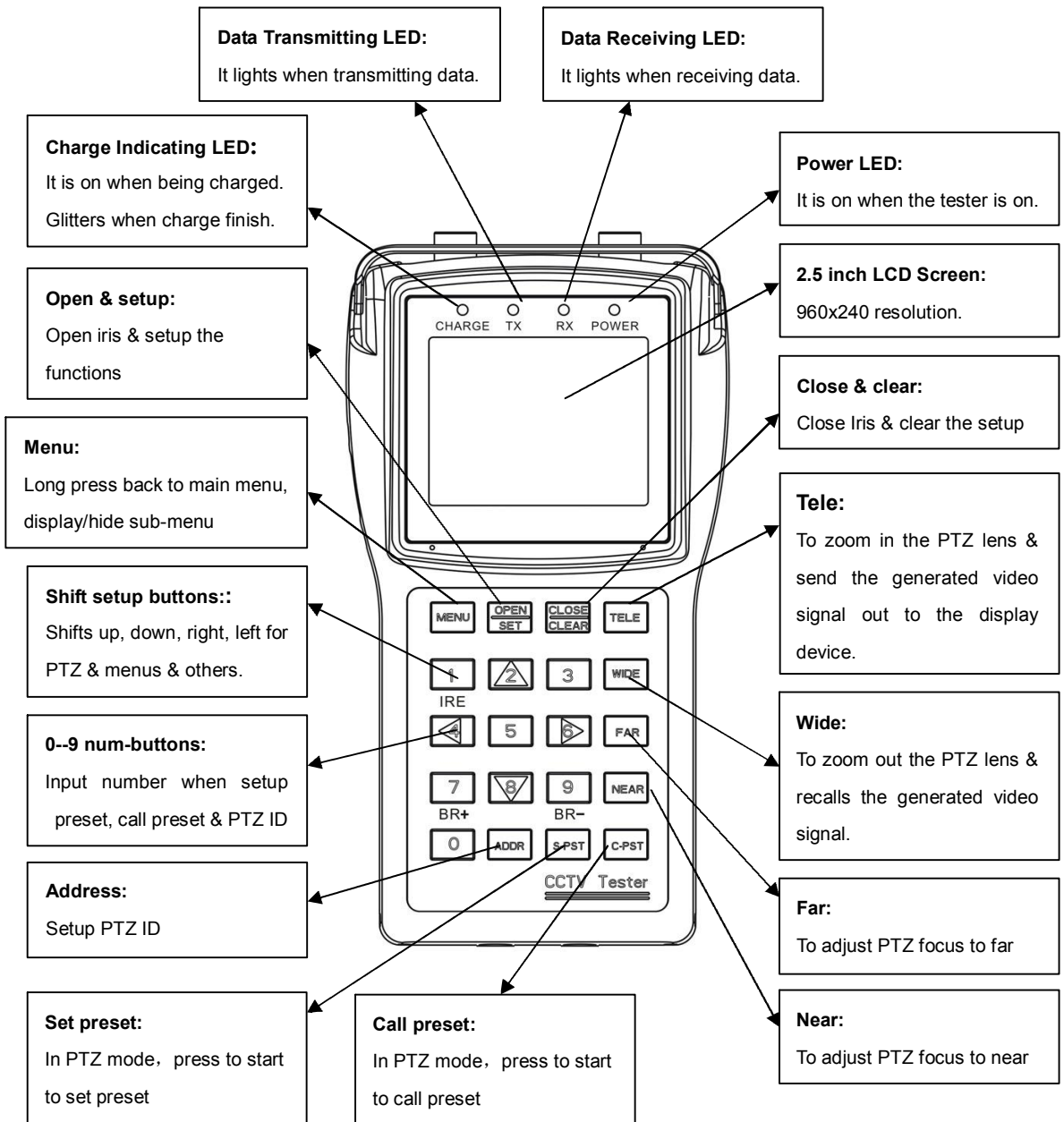

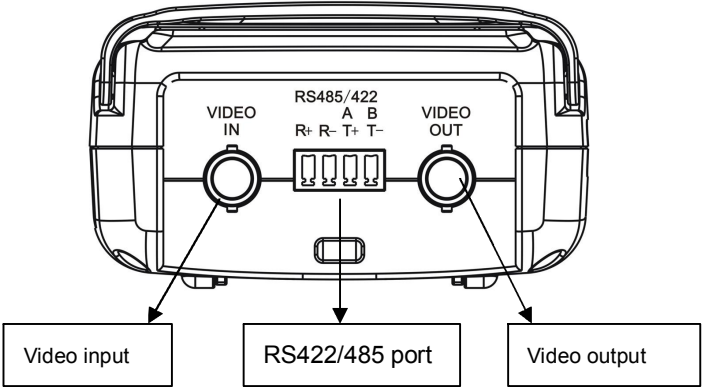
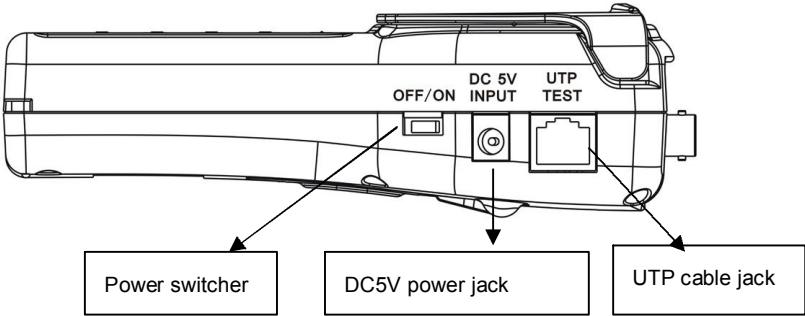
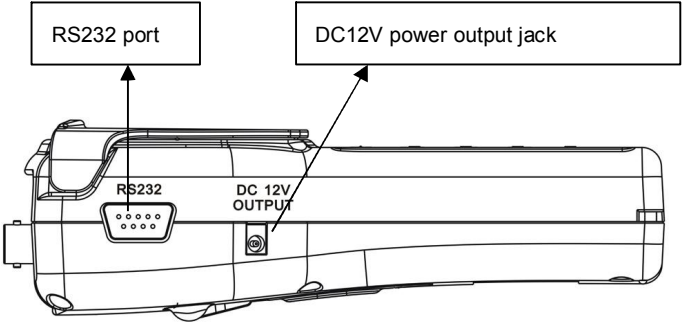

## 2.4 Specification

Model	CCTV-Test+	
Video Test	Signal Mode	NTSC / PAL input auto-detect
	Display	2.5 inch LCD screen, 960 x 240 resolution
	Video Input	1 channel BNC
	Video Output	1 channel BNC
	Adjustable	Brightness adjustable
PTZ Control and Test	Communication	RS232, RS422 simplex and RS485
	Protocol	Include more than 20 kinds of protocols
	Baud Rate	2400,4800,9600,19200
Multi-meter Function	DC Voltage Test	Max: 1000V, Precision: 0.1mV
	AC Voltage Test	Max: 750V, Precision: 0.1mV
	Resistance Test	Max: 40MΩ, Precision: 0.1Ω
Power to Camera	Voltage	DC12V
	Working Time	3~5 hours depending on load
	Max Current	400mA
Other Functions	Video analyzing	Video signal attenuation analyzing
	UTP Cable Test	Test UTP cable connection state
	Signal Generating	Output NTSC video signal for testing monitor
	RS485 Data Test	Test the RS485 data sent from controlling device
	OSD Menu	English OSD menu
Power and Battery	Keyboard	New design with number buttons, easy to operation
	Power Adapter	DC5V
	Battery	3000mAh rechargeable battery inside
	Rechargeable	6 hours recharging time
	Low Consumption	Sleeping mode, display battery power state
Others	Working Time	10 hours
	Work Temperature	-30℃---+70℃
	Work Humidity	30%-90%
	Dimension	166mm x91mm x48mm
	Weight	280g

## 3, Operation Introduction

### 3.1 Power and battery

- A. The power slide switch is located at the side of the tester. Turn the power slide switch on to power on the tester, turn it off to power off the tester;
- B. After the tester turning to sleeping mode, turn the slide switch on again to restart it;
- C. This tester has panel battery inside the device, more capacity, longer working time;
- D. Without the authorization from the manufacturer, please don't release the rear panel and try to repair the battery;
- E. The batteries should be plugged in over 5 hours for full charge, when charged the **Charge Indicating LED** will on, after full charging, the **Charge Indicating LED** light will off and the charging work can stop automatically.
- F. The charged batteries can operate for 10 hours or more.
- G. When the battery indicator in system information menu shows 25 (the status number includes 100, 90, 75, 50, 25, 5), please recharge it for use.
- H. The tester can be used when it is being charged.

### 3.2 Main menu introduction

Turn on the device; you will see the main menu, as the following shows:

- 1-5 are five independent sub-menu;
- Press the corresponding number button to get into the sub-menu;
- Version number and S/N cant be edited;

1 SYSTEM SETUP	——>	System information
2 PTZ CONTROLLING	——>	PTZ controlling function
3 UTP TESTING	——>	UTP testing function
4 VIDEO GENERATING	——>	Video generating function
5 RS485 DATA ANALYZING	——>	RS485 protocol analyzing
6 MULTI METER		
VER:V1.09      S/N:08110910	——>	Software version and S/N

### 3.3 Video test

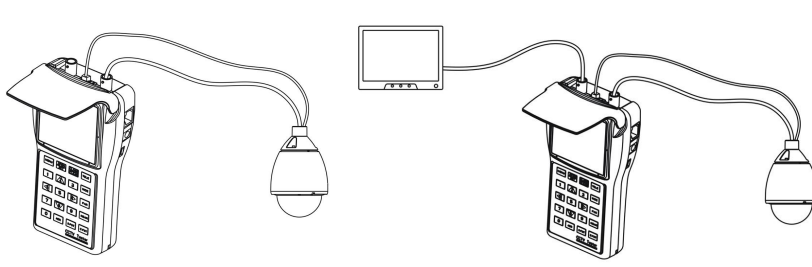

- A. Connect the output terminal of video output system to the video input BNC of tester, turn on the tester, the video can be display on the screen.
- B. Connect the video output BNC of tester to the video input of other display device, it can display the video signal generated by the tester or looped by tester.

### 3.4 System information sub-menu

- A. Press “1” to switch to the system information sub-menu, as follows:

PROTOCOL	Pelco P	——>	PTZ protocol
COM	485	——>	Communication port in used
RATE	4800	——>	Baudrate: 2400/4800/9600/19200
SPEED	016	——>	Pan and tilt speed
IDLE TIME	000	——>	Idle time from last operation to auto turn off (minute)
BATTERY	090	——>	Battery power status: 100/90/75/50/25/5

- B. Press **Set** button to start the set up:
- C. Press num-button “2” and “8” (PTZ direction button “UP” and “DOWN”) to select the option; (Battery power status can be edited)
- D. Press num-button “2/6/8” (PTZ direction button “UP/DOWN/RIGHT”) to adjust the parameter;
- E. Press num-button “4” (PTZ direction button “LEFT”) to save and quit;
- F. Press num-button “4” again to finish the setup situation, the characters in the menu will stop glitter;
- G. Press **MENU** button for 1 second to back to the main menu.

**Note:** In our device, PTZ there are 16 (some protocol ok has 7) levels for the PTZ, 0 means the minimum speed, 17 (or 7) means the maximum speed.

### 3.5 PTZ test

- A. **Connection**

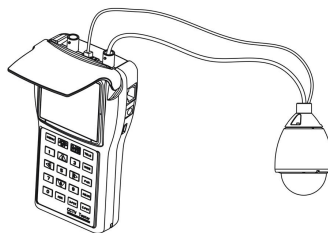

- Connect the tester with the PTZ camera as the picture shows.
- In the main menu, press num-button “2” to switch to the PTZ testing function



## B. Operation

- Press the **ADR** button, input the PTZ address by using num-button;
- Press the **SET** button to save the setup;
- Press the **MENU** button to hide the menu information and show a clean screen for camera image;
- Press **MENU** button for 1 second to back to the main menu.

## C. PTZ controlling

When connect to the PTZ correctly, the camera image will displayed in the screen of the tester, after setup the proper protocol, baud rate and the ID of the PTZ, user can control the PTZ as the following method:

- Press **UP/DOWN/LEFT/RIGHT** to control the movement of the PTZ;
- Press **OPEN/CLOSE** to control the iris;
- Press **FAR/NEAR** to adjust the focus manually;
- Press **WIDE/TELE** to zoom in/out the camera lens.

## D. Preset position

- Set up the preset position  
In the PTZ controlling mode, press **S-PST** button, then input the preset position number by the num-buttons, press **SET** to save the setup operation, user can use this method to set several preset positions one by one;
- Calling the preset position  
In the PTZ controlling mode, press the **C-PST** button, then input the preset position number by the num-buttons, press **SET** to save the setup operation, user can use this method to call several preset positions one by one;

## 3.6 Video signal attenuation analyzing

At the mode of video and PTZ testing, when there is a analogue video signal connect in and display in the screen correctly, press the num-button “1” to catch the parameter of video signal as:

- **MAX Vpp**: means the difference between maximum and minimum of video signal strength, the video signal will be brighter when this parameter is bigger.
- **AVERAGE Vpp**: means average of the difference between maximum and minimum

- of video signal strength.
- **SYNC SIGNAL:** means the voltage of the synchronic signal, user can use this signal to evaluate the impedance of coaxial cable. For example, if the synchronic signal number of camera is 0.3V (tested by tester in the camera side ), after a long distance transmission via coaxial cable, the synchronic signal number falls to 0.21V (tested again by tester ), this means the attenuation of video signal via this coaxial cable is 30%. User can evaluate if the quality of coaxial cable is good enough for this distance's usage.
- If there is no signal is detected, **"No Video"** will be displayed.

### 3.7 Screen brightness adjustment

At the mode of video and PTZ testing, user can press the num-button **"7" (BR+)** and **"9" (BR-)** to adjust the brightness of screen.

### 3.8 UTP cable test

A. Connect the tester to the UTP cable tester as the picture shows:

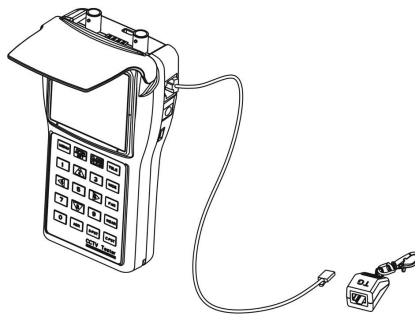

- B. In the main menu mode, press num-button **"3"** to switch to the UTP testing mode;
- C. Press **Set** to start the test, UTP cable information will be displayed in the screen.
- D. User can estimate the UTP cable connection situation from the information.

UTP CABLE TEST		
1	-----3	→ UTP tester side sequence
2	-----6	
3	-----1	
4	-----0	→ "0" means open circuit
5	-----0	→
6	-----2	
7	-----7	
8	-----8	

CCTV Tester side sequence ←

If there are 2 line show "0", it maybe:

- They open circuit separately;
- They short circuit to each other;

- E. User can estimate the connect situation base on the information;
- F. Press Menu button for 1 second to back to the main menu.

### 3.9 Video generating

- A. Connect the tester to the displayer device as the picture shows:

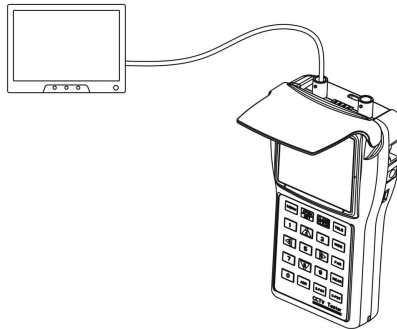

- B. In the main menu, press the num-button "4" to switch to the video **NTSC** generating function sub-menu, as the follows: **CCTV-Test+ does not generate Colour Bars**

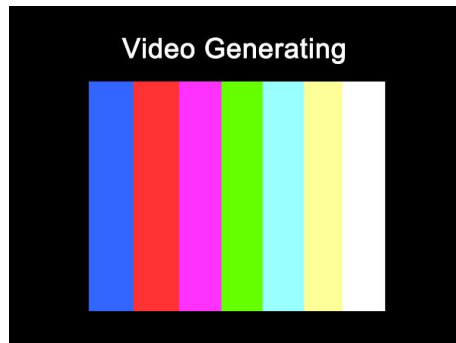

#### C. Operation setup

- Press num-button "4" to switch to the video generating function mode.
- Press **SET** to output the **NTSC Video Signal**: Blue, Green, White or Black.  
**CCTV-Test+ does not generate Colour Bars**
- Press **TELE** to send the generated video signal to the display device.
- Press **WIDE** to recall the generated video signal.
- Press **MENU** button in short time to hid/display the video generating menu character.
- Press **MENU** button for 1 second to back to the main menu.

### 3.10 RS485 data test

- A. Connect the tester to the controlling device as the picture shows:

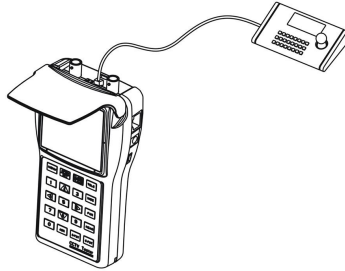

- B.** In the main menu, press num-button “5” to switch to the RS485 protocol analyzing mode, as follows:



- C.** Press **SET** to start the setup of baud rate.  
**D.** Press **UP/DOWN** to select the tester’s baud rate, make it same with the controlling device’s. baud rate in using.  
**E.** Make the controlling device transfer the RS485 data to the tester, the hexadecimal signal data will displayed in the screen as follows, engineer can analyze the data to know if the controlling device work with the correct protocol.

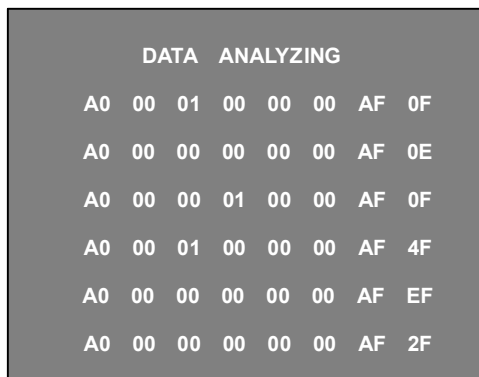

### 3.11 Digital multi-meter

- A.** Connect the 2 detecting cable on the tester as the picture shows:

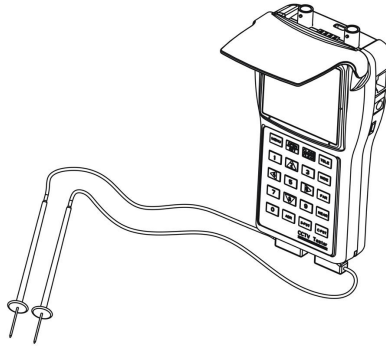

B. Press the num-button “6” to go to the multi-meter sub-menu as follows:

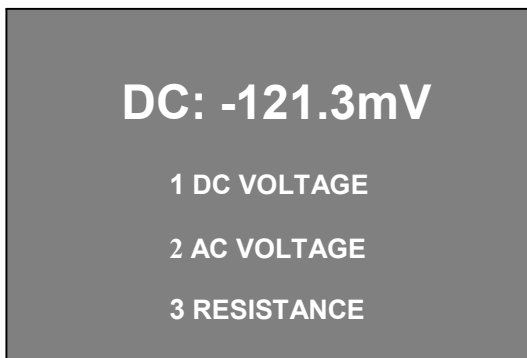

C. Press the num-button 1,2,3 can select the corresponding option:

- DC voltage test range: 0-1000V, precision: 0.1mV;
- AC voltage test range: 750V, precision: 0.1mV;
- Resistance test range: 0-40M $\Omega$ , precision: 0.1 $\Omega$ .

D. Press **MENU** button for 1 second to back to the main menu.

**Note:** Please don't test the voltage over the testing range, it can make the tester broken.

### 3.12 Output power to camera

Connect the camera with the tester as the picture shows, connect the DC12V output from tester to the DC12V input port from the camera using the accessory “**DC12V power cable**”

